



Cuisine Solutions Investigation Update

CSB Public Meeting
January 23, 2025



U.S. Chemical Safety and
Hazard Investigation Board

Incident Summary

- Cuisine Solutions uses ammonia refrigerant for process cooling and to operate industrial freezers
- July 31, 2024, at ~ 8:20 pm
- Anhydrous ammonia release through emergency pressure relief valve
- 40 evaluated at local medical facilities
 - 36 evaluated and released
 - 4 admitted to hospital
 - Of the 4, 1 in ICU

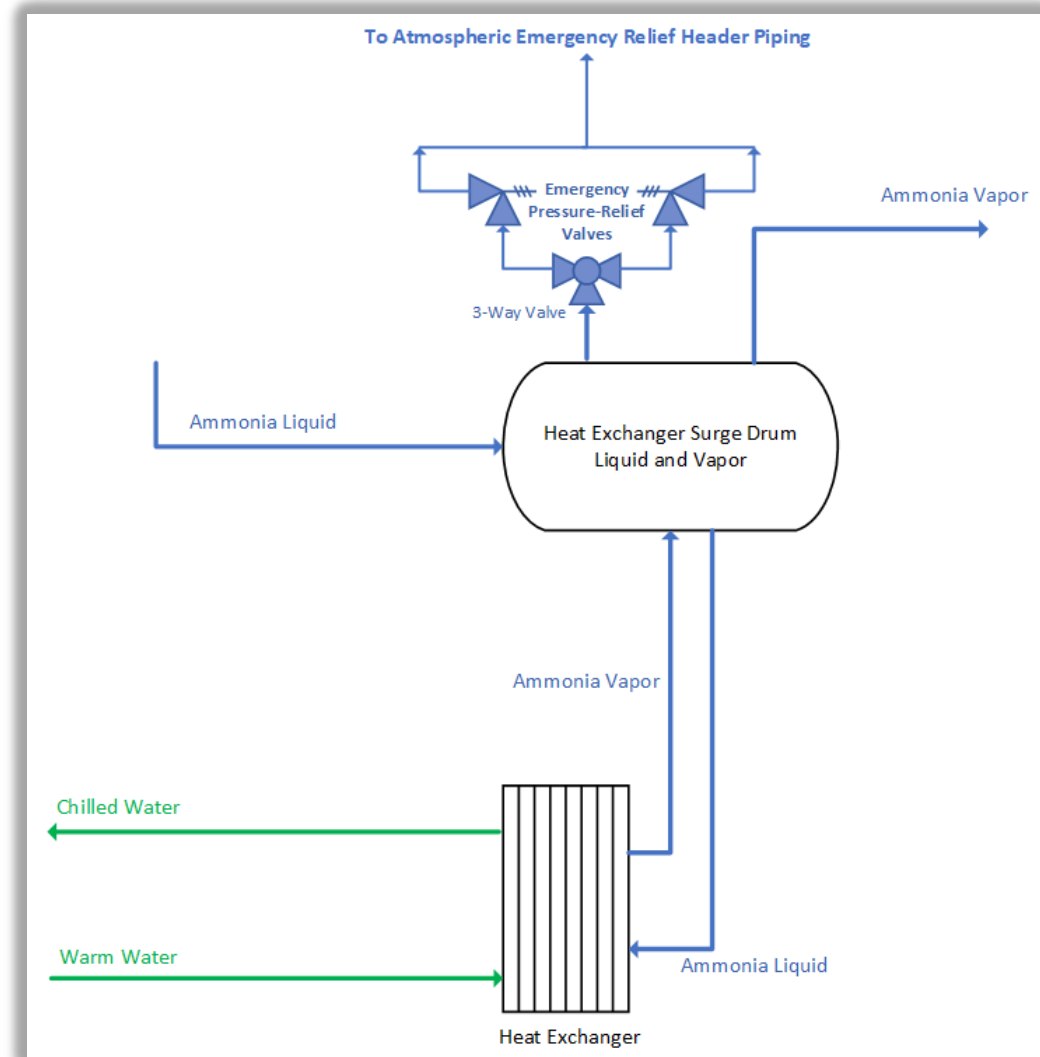



The Release

Ammonia exiting the relief discharge, condensing atmospheric moisture.

Evacuation Routes

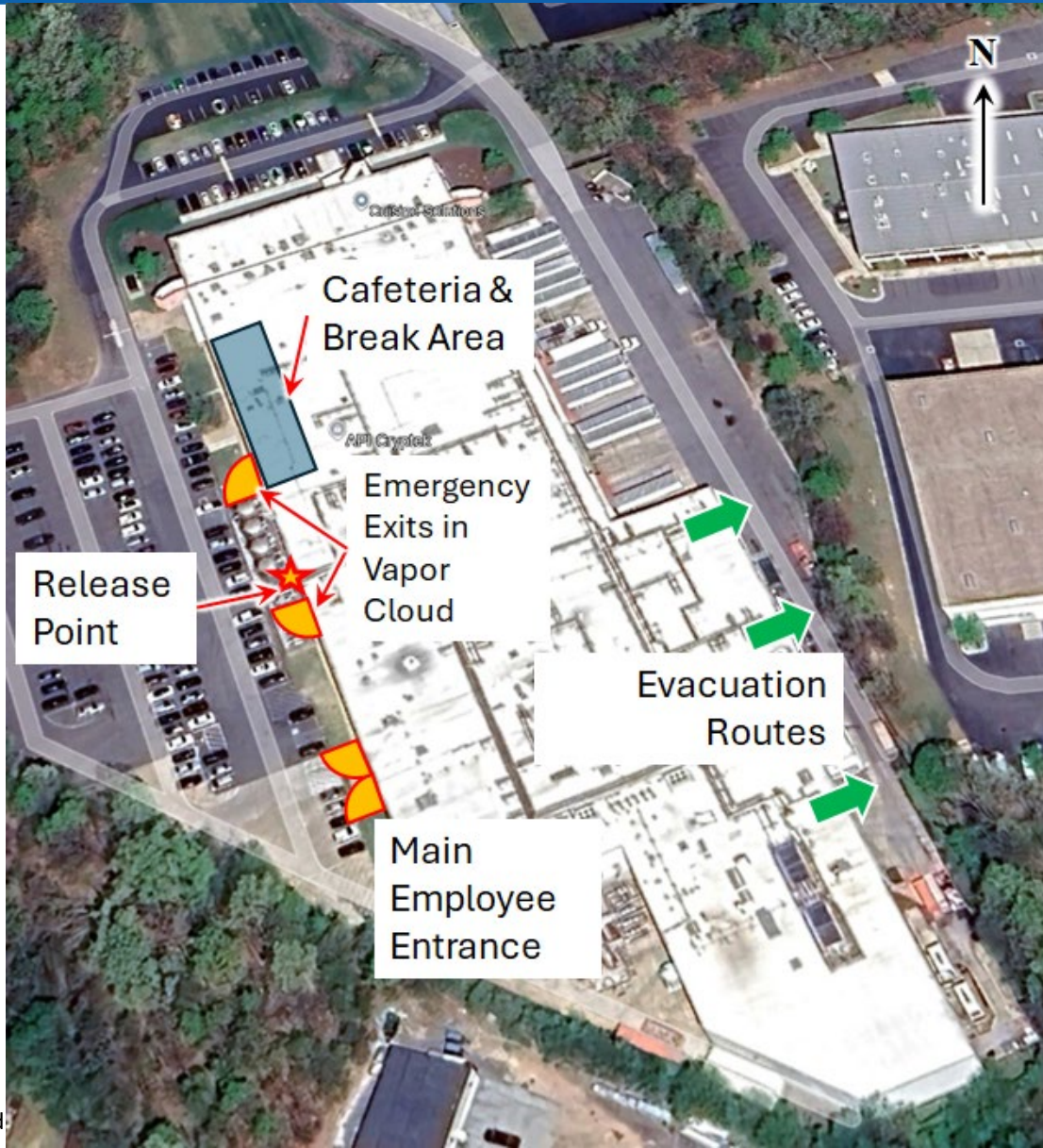



U.S. Chemical Safety and
Hazard Investigation Board



For more information

Go to [csb.gov/cuisine-solutions-ammonia-release/](https://www.csb.gov/cuisine-solutions-ammonia-release/)